



We make it *possible*



NAVY SHOCK MOUNTING SYSTEMS

NAVY SHOCK MOUNTING SYSTEMS

INTRODUCTION

A shock mounting system must fulfil the following functions :

- supporting the suspended mass when there is no shock while providing isolation from vibration and structure borne noise;
- in case of shock: limit the force and/or movement to acceptable values;
- after shock : return the suspended mass to its initial position.

Schematically, there are two types of shock :

- an energy shock resulting from a falling mass for which the parameters taken into consideration are the incident kinetic energy and that restituted, the impact speed and the maximum forces and deflections.
- a shock resulting from a movement of the suspended mass. The parameters taken into consideration are the speed or acceleration of the assembly in time and also the forces relating to the maximum deflection.

STANDARDS APPLICABLE TO THE MARINE MOUNTS

Reference*	Applications
BR 3021	Shock for onboard equipment
BR 8470	
BV 043	Shock for surface ships and submarines
DIN 95365	Marine mounts geometry and characteristics
GAM-EG-13C	Vibration and shock onboard ship
MIL-S-901D	Shock for onboard equipment
MIL-STD-167	Marine equipment vibrations
STANAG 4142	Shock resistance analysis of equipment for surface ships
STANAG 4549	Testing of surface ship equipment on shock testing machines
STI-MM-305	Vibration and shock testing for onboard equipment

* For compliance with these standards according to the applications, ask our Technical Department.

ADVANTAGES

- The mountings described below are intrinsically stable under shock, that is to say, they enable the mass to return to its initial position; the system retains no plastic deformation nor residual buckling when the shock stresses are removed.
- The suspended mass may therefore undergo successive shocks with impunity. Nevertheless, the stability of the assembly in relation to the relative positions of the mountings and the centre of gravity of the suspended mass should be checked.
- PAULSTRA shock mounting systems are also exceptionally effective against vibration.

VIB LD 03 DECOUPLING WASHERS



DESCRIPTION

Elastomer rings for linking and positioning of equipment while maintaining acoustic discretion and protection from shocks.

A decoupling washer is composed of :

- Two bonded elastomer washers;
- One stainless steel anti-shock washer;
- One stainless steel preload spacer.

CHARACTERISTICS

- Natural frequencies (vertical and axial) 15 to 20 Hz depending on load.
- Maximum deflection under shock:
 - axial : 8 mm;
 - radial : 5 mm.
- Mechanical strength corresponding to 30 times the nominal load.

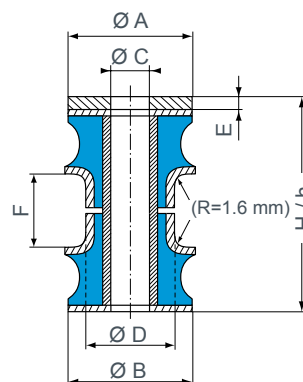

Nominal load (daN)	Reference	Ø A (mm)	Ø B (mm)	Ø C (mm)	Ø D (mm)	E (mm)	F (mm)	H unloaded (mm)	h under load (mm)
14	E1RP-3804-51	Square 28x28	28	8,2	20	2,5	10	42,5	35,5 approx
18	E1RP-3804-52	Square 28x28	28	8,2	20	2,5	10	42,5	35,5 approx
27	E1RP-3805-51	Square 28x28	28	8,2	20	2,5	10	42,5	35,5 approx
40	E1RP-3806-51	42,5	42,5	14,2	29	5	15	50	44 approx
60	E1RP-3806-52	42,5	42,5	14,2	29	5	15	50	44 approx
85	E1RP-3806-53	42,5	42,5	14,2	29	5	15	50	44 approx
125	E1RP-3807-51	56	56	18,2	35	8	15	53	47 approx
140	E1RP-3807-52	56	56	18,2	35	8	15	53	47 approx
185	E1RP-3807-53	56	56	18,2	35	8	15	53	47 approx
260	E1RP-3808-51	78	80	24,5	50	12	25	67	60,5 approx
320	E1RP-3808-52	78	80	24,5	50	12	25	67	60,5 approx
380	E1RP-3808-53	78	80	24,5	50	12	25	67	60,5 approx
520	E1RP-3809-51	88	90	27,5	53	16	25	71	64,5 approx
1000	E1RP-3809-53	88	90	27,5	53	16	25	71	64,5 approx
2000	E4353F-51	220	220	60	125	35	48,9	120,9	112,9 approx
3500	E4353F-52	200	200	60	125	35	48,9	121,9	113,9 approx

LOW DEFLECTION MOUNTS

LOW LOADS



DESCRIPTION

The main role of these mounts is to isolate vibration. A snubber system limits the movement of the suspended mass (10 mm), however the loads developed in this case, are high.

A wide load range from 0,5 to 32 daN depending upon the application.

In case of shock protection, the structural resistance of the mount can accept acceleration of up to 150 g. These mounts are mainly suited for vibration, hence the loads generated in case of shock are very high.

Fixation on the inside or on the outside.

CHARACTERISTICS

- Natural frequencies (vertical and lateral) under a nominal load of 5 to 8 Hz.
- B = unloaded.
- B - 6 mm height under nominal load (deformation under load . 6 mm).
- Maximum deflection from loaded position ± 10 mm in all directions (vertical and lateral).
- Stop at 10 mm deflection, maximum acceptable loads = 150 x nominal static load.

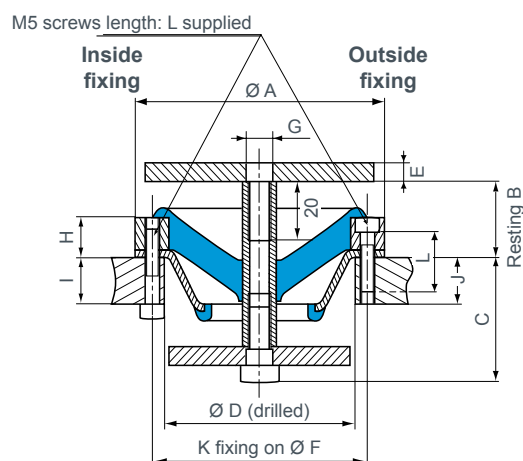

Nominal static load (daN)	Reference	Ø A (mm)	B (mm)	C (mm)	Ø D (mm)	E (mm)	Ø F (mm)	G	H (mm)	I (mm)	J max. (mm)	K	L max. (mm)
0,5	552320 50 14	66	30	25,5	48	2,5	56	M6	12	8 10	15	3	20
1	552320 50 04	66	30	25,5	48	2,5	56	M6	12	8 10	15	3	20
2	552321 50 04	66	30	25,5	48	2,5	56	M6	12	8 10	15	3	20
4	539966 50 04	82	31,5	34,5	63	5	71	M8	13,5	6,5 11	20	3	20
8	539967 50 04	82	31,5	35,5	63	6	71	M8	13,5	6,5 11	20	3	20
16	539985 50 24	82	51	32	63	8	71	M12	33	10 15	20	4	40
24	539985 50 04	82	51	32	63	8	71	M12	33	10 15	20	4	40
32	539985 50 14	82	51	32	63	8	71	M12	33	10 15	20	4	40

VIBMAR

Natural frequency : (1)
5 to 12 Hz



DESCRIPTION

The VIBMAR series has a base plate with two or four mounting holes and a tapped steel core. The elastomer is bonded to the steel.

E1N104 and E1N106 versions have a conical spring embedded in the rubber.

Environmental protection is provided by painting the metal parts and by coating the elastomer with an ozone resistant compound.

APPLICATIONS

These multi-axis low frequency dampers have been specially designed to protect electrical or electronic racks and marine or road transport generator sets (on board or not). They are cone-shaped to absorb considerable displacement and shocks.

1) the indicated natural frequency, are valid for the maxi loads of the ranges of use quoted in the paragraph : TECHNICAL CHARACTERISTICS.

VIBMAR E1N2296

DIMENSIONS

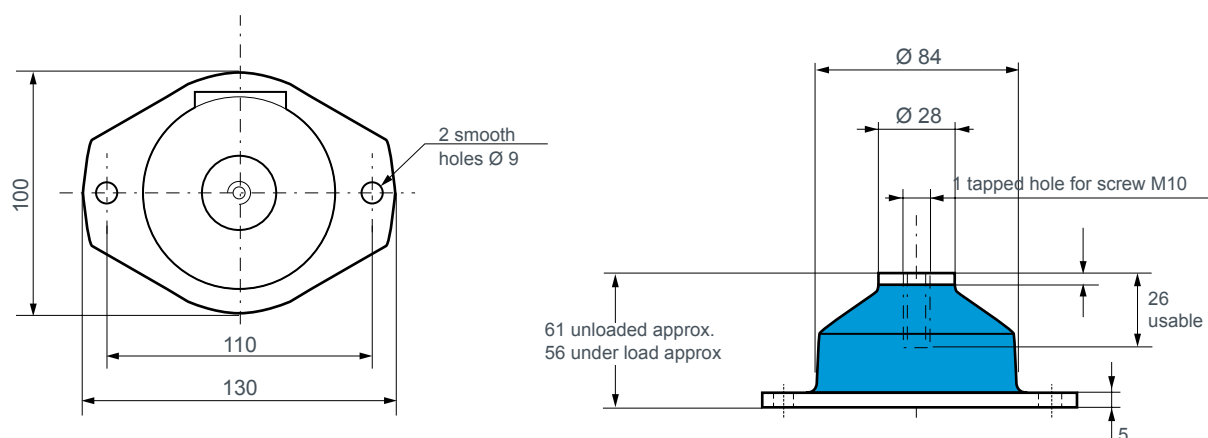

OPERATING CHARACTERISTICS

Natural frequency :

- axial : 8 to 12 Hz;
- radial : 6 to 10 Hz.

Maximum permitted excitation at the natural frequency of suspension : ± 1.25 mm.

Maximum axial travel available for shocks : 30 mm.

Amplification factor at resonance : < 6 and < 4 for silicone rubber versions.

Structural strength corresponding to a continuous acceleration of 3 g with maximum load.

When suspending an enclosure, the same type of damper should be used as a stabiliser.

Operating temperature : - 30°C to + 100°C;
 - 54°C to + 150°C for silicone rubber versions.

Weight : 0.6 kg.

SILICONE RUBBER

Reference	Static load (daN)
E1N2296-01	17-30
E1N2296-02	35-55
E1N2296-03	55-70

Reference	Static load (daN)
E1N2296 S01	10-18
E1N2296 S02	17-25
E1N2296 S03	20-30

Note : Product available with stainless steel plates and/or alternative elastomers.
 Please consult us

VIBMAR E1N101

DIMENSIONS

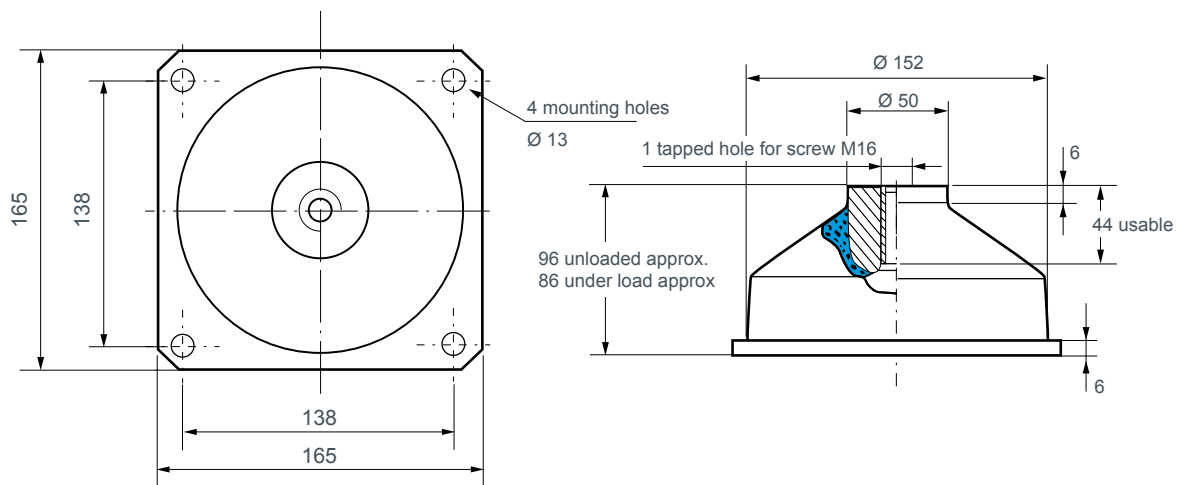

OPERATING CHARACTERISTICS

Natural frequency :

- axial : 5 to 6 Hz;
- radial : 4 to 6 Hz.

Maximum permitted excitation at natural frequency of suspension : ± 1.5 mm.

Maximum travel available under shocks : 30 mm in all directions

Weight : 2 kg.

Reference	Axial static load (daN)
E1N101-01	50 - 85
E1N101-02	85 - 120
E1N101-04	130 - 210
E1N101-05	210 - 310
E1N101-06	310 - 530

Note : Product available with stainless steel plates and/or alternative elastomers on special request. Please consult us.

VIBMAR E1N104 - E1N106

DIMENSIONS

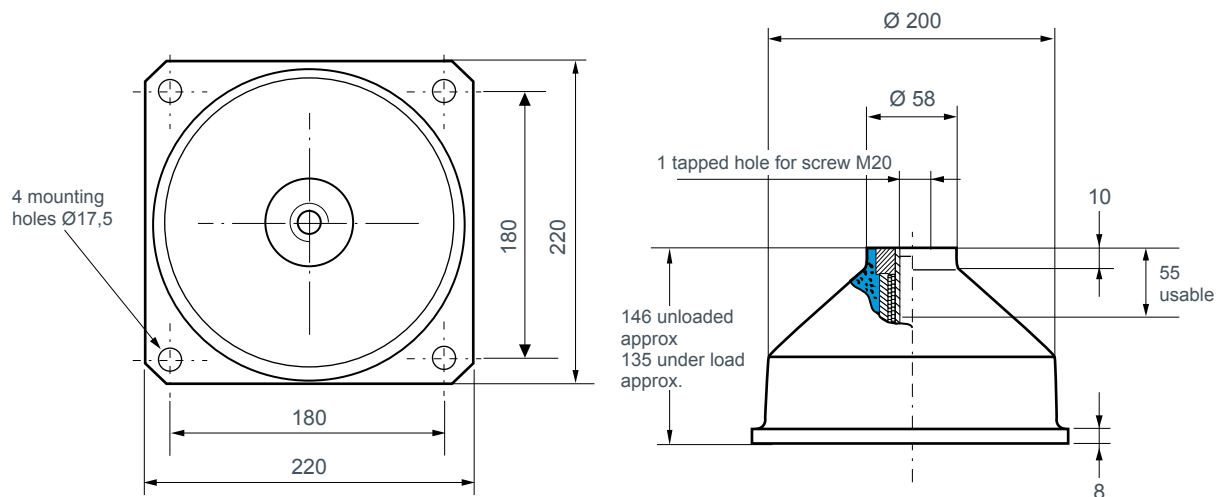

OPERATING CHARACTERISTICS

Natural frequency :

- axial : 5 to 7 Hz;
- radial : 6 to 8 Hz.

Maximum permitted excitation at the natural frequency of suspension : ± 1.5 mm.

Amplification factor at resonance : $4 < Q < 10$.

Maximum axial travel available under shocks :

- axial ± 45 mm;
- radial ± 25 mm.

Structural strength corresponding to a continuous acceleration of 10 g with maximum load.

Weight : 2 kg.

Reference	Axial static load (daN)
E1N104C45AS	200 - 360
E1N104C60AS	360 - 600
E1N104C75AS	500 - 800
E1N106C60AS	700 - 1000
E1N106C75AS	900 - 1300

VIB HD 50

MEDIUM DEFLECTION MOUNTS

LOW LOADS



DESCRIPTION

The permitted deflection (40 to 50 mm) of the suspended mass in relation to the mounting base limits reaction under shock. No efficient vibration protection is offered during shock.

CHARACTERISTICS

- Natural frequency (vertical and lateral) under load of 5 to 8 Hz.
- Maximum deflection under load :
 - vertical : ± 50 mm*;
 - lateral : ± 45 mm*.
- H in rest position.
- H - 6 mm under nominal load (deflection under load = 6 mm).

* maximum forces corresponding to 10 times the load.

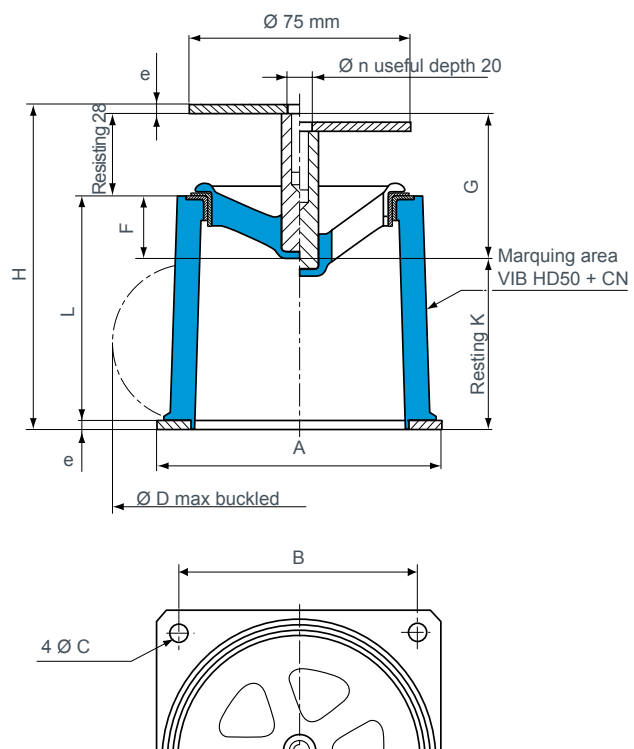

Nominal static load (daN)	Reference	□A (mm)	H (mm)	□B (mm)	e (mm)	Ø C (mm)	Ø n (mm)	F (mm)	G (mm)	Ø D (mm)	L (mm)	K (mm)
1	552301 50	90	109	75	2	5,5	8	19	47	105	77	60
2	552302 50	90	109	75	2	5,5	8	19	47	110	77	60
4	552303 50	95	110	80	3	5,5	8	21	49	120	76	58
8	552304 50	95	110	80	3	5,5	8	21	49	120	76	58
16	552305 50	105	129,5	90	5	6,5	12	39,5	67,5	125	91,5	57
24	552306 50	105	129,5	90	5	6,5	12	39,5	67,5	130	91,5	57
32	552307 50	105	129,5	90	5	6,5	12	39,5	67,5	135	91,5	57

VIB HD 45 HIGH DEFLECTION SHOCK MOUNTS



DESCRIPTION

Range of omnidirectional high deflection shock mounts made with a square base plate and a threaded core on the upper side.

The elastomer, in natural rubber, is developed especially for navy applications (other materials on demand).

ADVANTAGES

These mounts provide both high level of vibration isolation and shock protection. Its high structural strength corresponds to a continuous acceleration of 10 g under maximum load.

The range includes 17 different mounts covering a wide load range from 15 kg up to 1670 kg per mount.

This mount meets the latest US and European shock standards in use in the naval forces across the globe.

The metalworks are protected against corrosion (ie. : salt spray).

DIMENSIONS

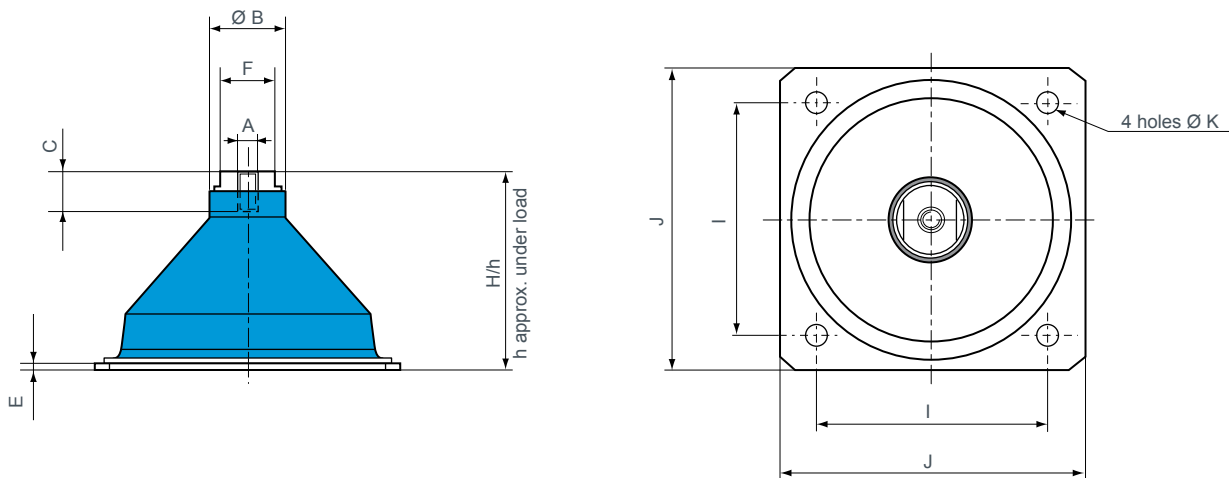

OPERATING CHARACTERISTICS

Nominal load (daN)	Load range (daN)	Part number	A	Ø B (mm)	C useful lenght (mm)	H unloaded (mm)	h /s under load (mm)	E (mm)	F (mm)	I (mm)	J (mm)	Ø K screw hole (mm)
30	15 to 35	E1N-3628-52	M10	37	20	100	89	5	27	114	150	9
45	23 to 52	E1N-3628-51	M10	37	20	100	89	5	27	114	150	9
60	30 to 69	E1N-3454-54	M10	37	20	100	89	5	27	114	150	9
85	43 to 98	E1N-3454-53	M10	37	20	100	89	5	27	114	150	9
110	55 to 126	E1N-3454-52	M10	37	20	100	89	5	27	114	150	9
130	65 to 150	E1N-3454-51	M10	37	20	100	89	5	27	114	150	9
165	83 to 190	E1N-3454-56	M10	37	20	100	89	5	27	114	150	9
170	85 to 196	E1N-3455-54	M20	54	40	126	115	10	41	140	165	13
230	115 to 265	E1N-3455-53	M20	54	40	126	115	10	41	140	165	13
320	160 to 370	E1N-3455-52	M20	54	40	126	115	10	41	140	165	13
425	213 to 490	E1N-3455-51	M20	54	40	126	115	10	41	140	165	13
560	280 to 645	E1N-3455-56	M20	54	40	126	115	10	41	140	165	13
500	250 to 575	E1N-3456-54	M24	116	48	154	141	15	41	210	250	18
625	313 to 720	E1N-3456-53	M24	116	48	154	141	15	41	210	250	18
800	400 to 920	E1N-3456-52	M24	116	48	154	141	15	41	210	250	18
1080	540 to 1212	E1N-3456-51	M24	116	48	154	141	15	41	210	250	18
1450	725 to 1670	E1N-3456-55	M24	116	48	154	141	15	41	210	250	18

- Vertical nominal static load : from 15 kg to 1670 daN per mount.
- Axial and radial natural frequencies : 4 to 8 Hz, depending on the load (see chart).
- Maximum axial shock displacement : 45 mm (can be increased up to 63 mm with the addition of washers).
- Maximum radial shock displacement : 45 mm.
- Structural strength : 10 g under maximum load.
- Operating temperature : - 30°C to + 80°C.

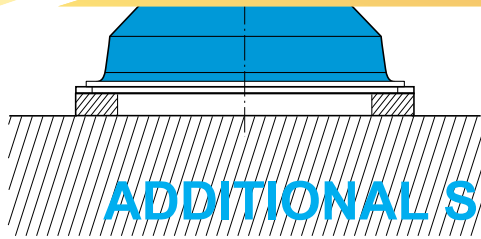

ADDITIONAL SPACERS

Washer for the mounting plate *

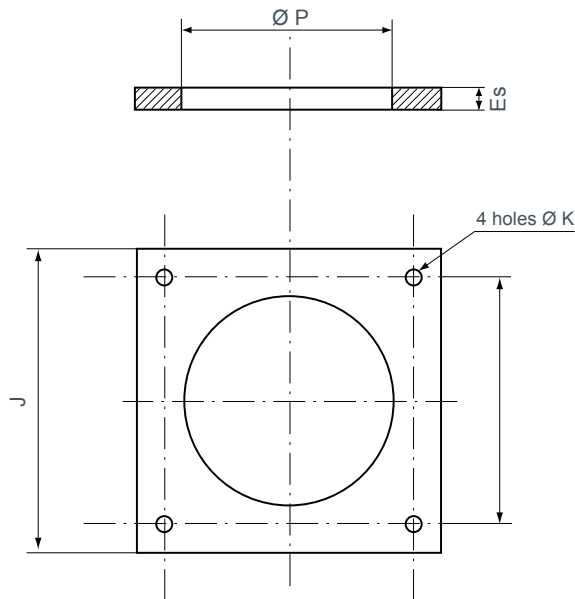

Washer for the threaded core *

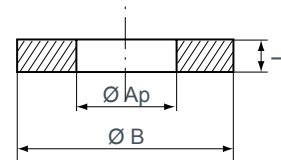

* Not supplied

For the part number	Max. axial displacem. (mm)	Washer for the mounting plate					Washer for the threaded core		
		Thickness Es(mm)	$\varnothing P$ (mm)	J (mm)	I (mm)	$\varnothing K$ (mm)	$\varnothing B$ (mm)	$\varnothing A_p$ (mm)	Height L (mm)
E1N-3628-XX	63	8	88	150	114	9	37	11	10
E1N-3454-XX	63	8	88	150	114	9	37	11	10
E1N-3455-XX	67	5	105	165	140	13	54	22	10
E1N-3456-XX	69	5	130	250	210	18	116	26	10

Installation without washer

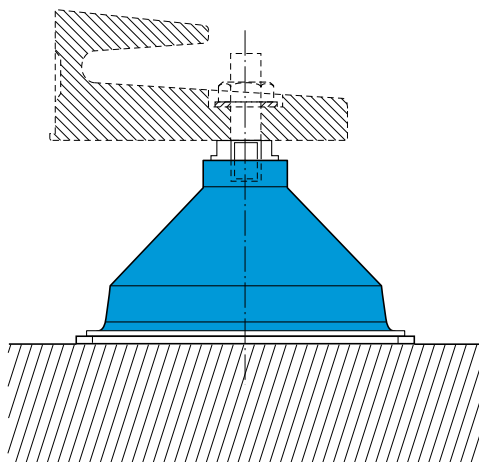

Installation with washers

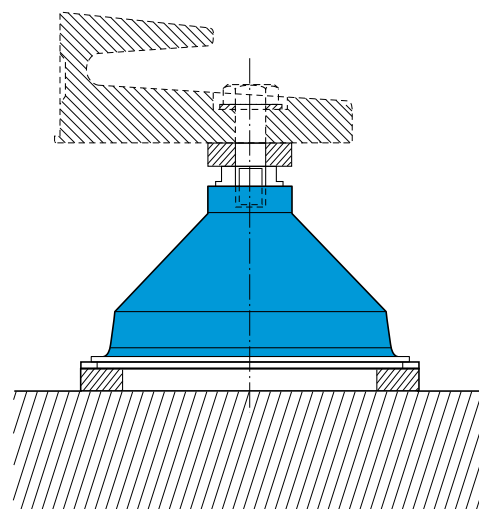

ASSEMBLY

These parts are designed to be loaded in compression. they have to be installed on a flat surface covering the entire surface of the base plate. The supported structure is then secured to the central core using a high tensile screw M20.

For a better result, the load per mount should be evenly distributed. In the case of a tall suspended equipment, these mounts can be used as stabilizing devices. They will be secured to the equipment only after stabilization of the base mount.

These mounts are not designed to carry a permanent load in shear or in tension.

All connections with the suspended equipment must be flexible and capable to accept high displacement allowing the suspensions to work properly.

We strongly recommend to have your installation approved by our technical department before ordering the mounts.

Assembly drawings

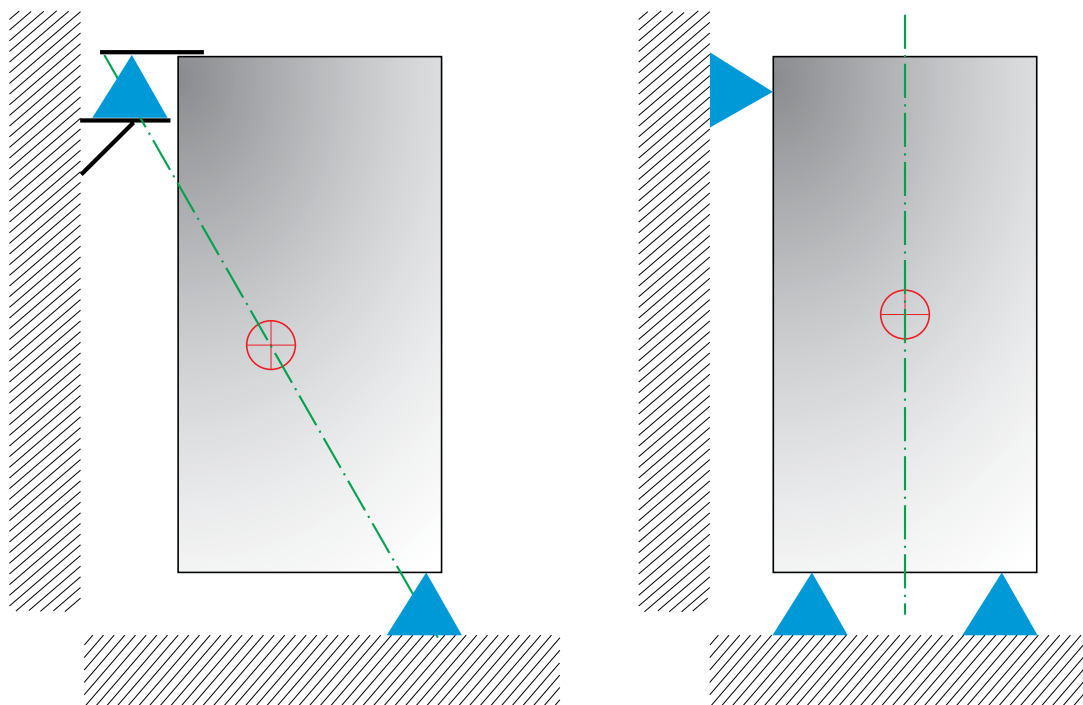

VIB HD 56

MEDIUM DEFLECTION MOUNTS

HIGH LOADS



DESCRIPTION

A complete range of high deflection omnidirectional mounts. They are made of two cast iron inserts, a threaded steel plate holding the fixing interfaces is added to one end.

The elastomer is a specially developed natural rubber to meet the navy requirements (Other materials can be delivered on request).

ADVANTAGES

These mounts will provide both a very high level of vibration attenuation and a high shock capacity to reduce the transmitted acceleration. It's structural resistance correspond to a continuous acceleration of 10 g at the maximum load.

The range is made of several references with a load range ranging from 1125 daN up to 7000 daN per mount.

These mounts meet both the European and North American shock standards.

The metalwork are treated against corrosion.

DIMENSIONS IN mm (for Shapes 1 & 2)

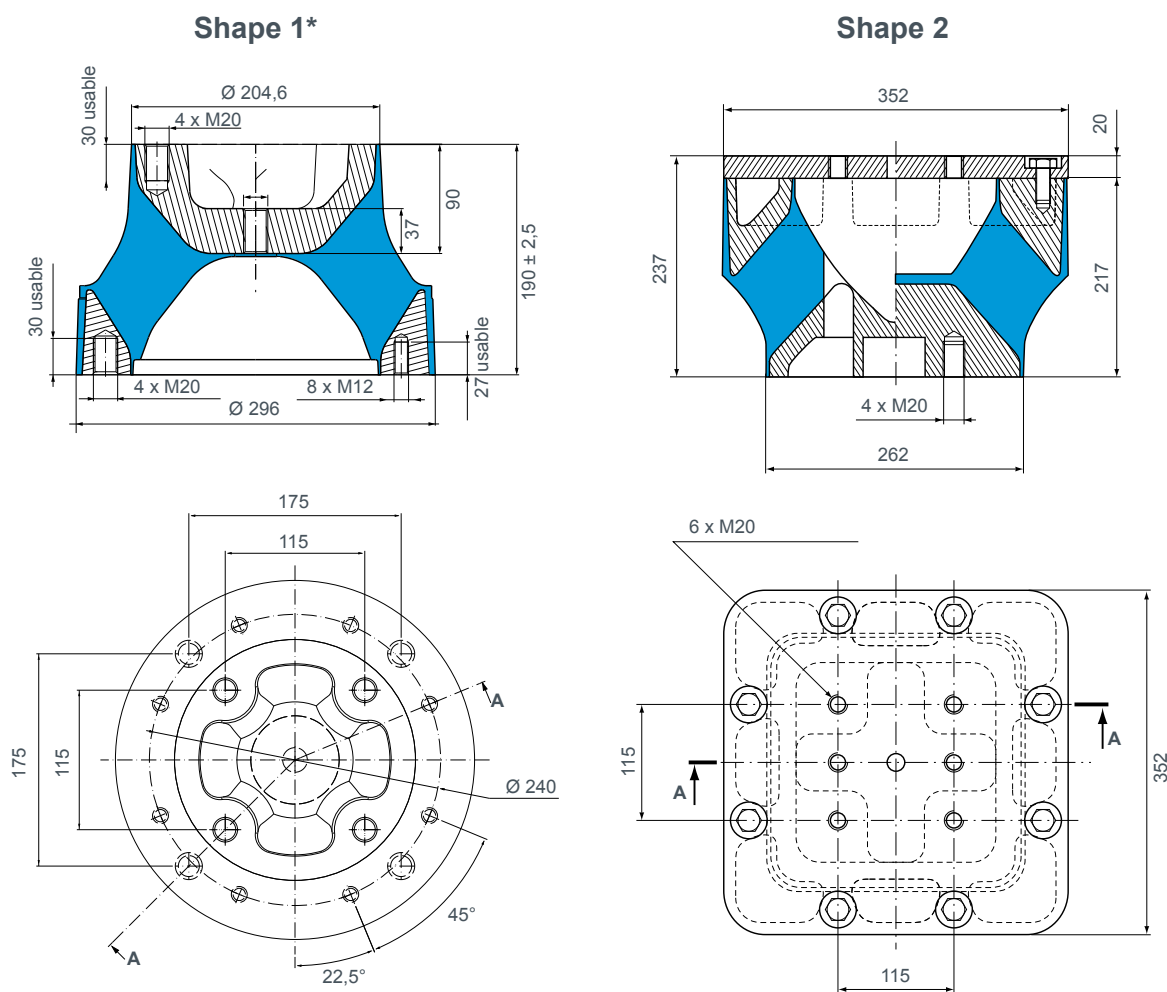

OPERATING CHARACTERISTICS (for Shapes 1 & 2)

Load range (daN)	Reference	Shape	Height under max. load (mm)
850 to 1955 1050 to 2415 1250 to 2875 1600 to 3680	E1N-4001-54 E1N-4001-52 E1N-4001-53 E1N-4001-51	1	177 ± 2
3000 to 5000 4200 to 7000	E1N-4066-52 E1N-4066-51	2	220 ± 2

- Static nominal load : 1125 to 7000 daN per mount.
- Axial and radial natural frequency : 4 to 7 Hz depending on load.
- Displacement under shock : 56 to 60 mm depending on the axis.
For the E1N-4001 mount, it can be increased to 63 mm using spacers.
- Structural strength : 10 g at maximum load.
- Temperature range : - 30°C up to + 80°C.

* Geometry evolution. Please consult us.

ASSEMBLY

These mounts are designed to carry load in compression and should be installed on a smooth surface. The equipment in Men second using 4 M20 bolts (shapes 1 and 2).

For a better result, the load per mount should be evenly distributed. In the case of a tall suspended equipment, these mounts can be used as stabilizing devices. They will be secured to the equipment only after stabilization of the base mount.

These mounts are not designed to carry a permanent load in shear or in tension.

All connections with the suspended equipment must be flexible and capable to accept high displacement allowing the suspensions to work properly.

We strongly recommend to have your installation approved by our technical department before ordering the mounts.

Assembly drawings

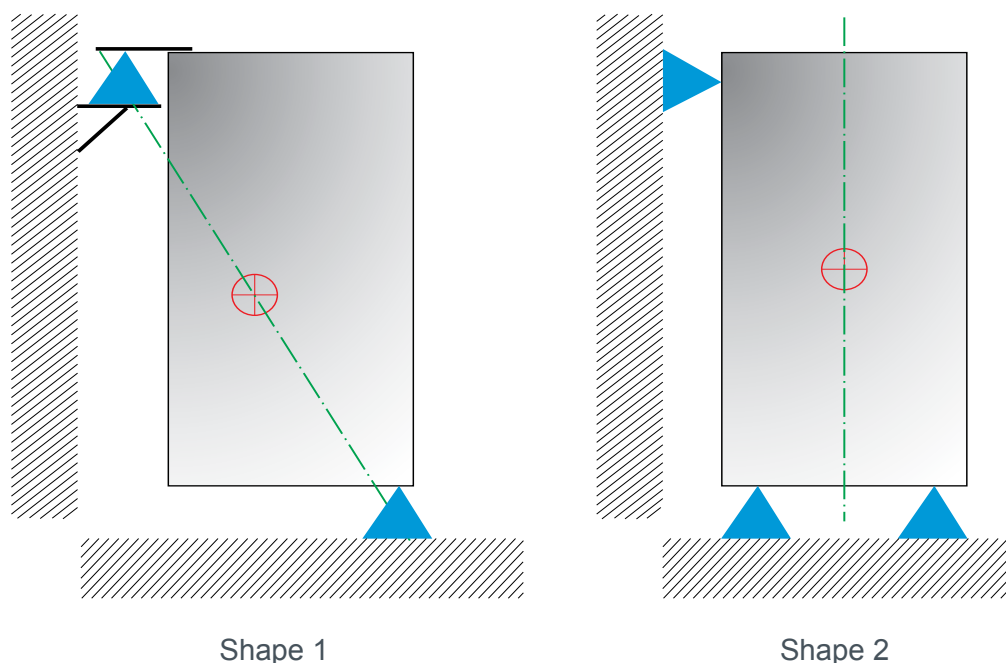

GB 530 MOUNTS

Natural frequency : (1)
5 Hz



DESCRIPTION

The GB530 comprises of one part in elastomer bonded to a base plate and a tapped steel core (a non magnetic version is also available).

Advantages

- Can provide high deflection under shocks.
- Long life.
- Low natural frequency (5 Hz in axial).
- Low amplification at resonance.(8 at 10)

APPLICATIONS

These are specific mounts created for the naval industry : on board electronics, radars, special weapons equipment.

DIMENSIONS

Dimensions are given in mm.

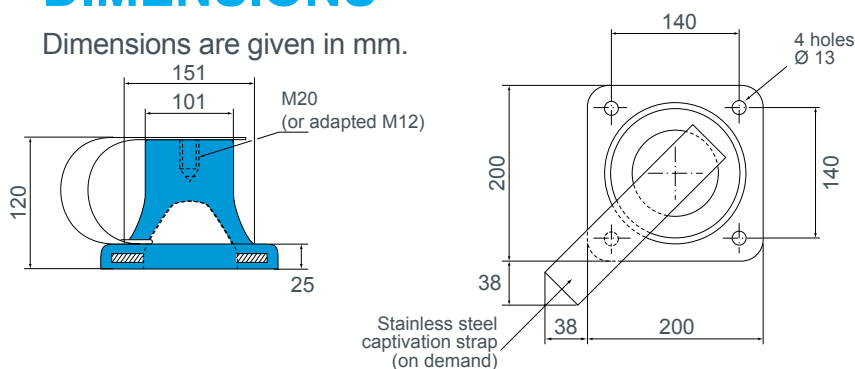

OPERATING CHARACTERISTICS

Paulstra reference	Barry Controls * reference	Load range (daN)
530901 21 00	GB530-NR1	7,5 - 75
530901 21 10	GB530-NR2	15 - 150
530901 21 20	GB530-NR3	25 - 250
530901 21 30	GB530-NR4	40 - 400
530901 21 40	GB530-NR5	60 - 600

Temperature range :
-30° C to + 70°C
Weight : 3 - 4 kg

* Barry Controls part numbers are given as a reference.

1) the indicated natural frequency, are valid for the maxi loads of the ranges of use quoted in the paragraph : TECHNICAL CHARACTERISTICS.

“X” TYPE FLEXIBLE MOUNTS

Natural frequency : (1)
4 to 10 Hz



DESCRIPTION

Steel mounting with excellent shock absorption capacity, highly resistant to fatigue. It is made of a stainless steel and epoxy resin sandwich which limits the amplification.

DIMENSIONS

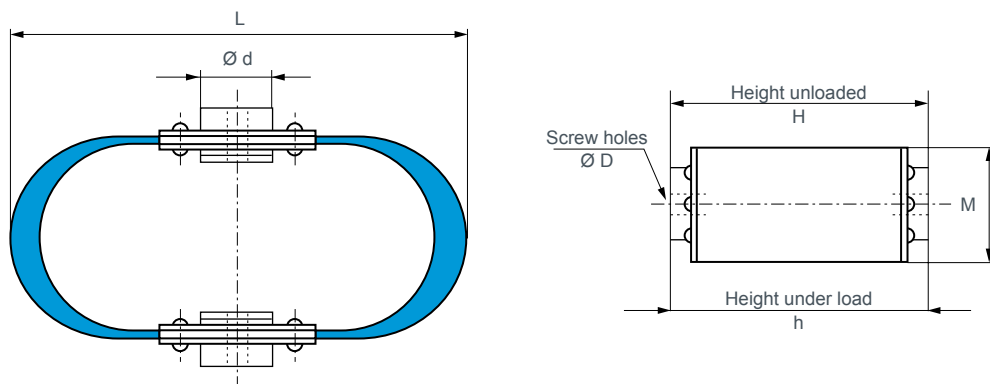

Reference	Nominal load (daN)	H (mm)	h (mm)	L (mm)	M (mm)	Ø d (mm)	Ø D (mm)
E1M-3950-01	10	114,3	106,9	203,2	50,8	31,8	8
E1M-3951-01	20	114,3	106,9	203,2	50,8	31,8	8
E1M-3952-01	45	133,3	123,2	215,9	50,8	31,8	12
E1M-3953-01	70	133,3	123,6	215,9	50,8	31,8	12
E1M-3954-01	110	133,3	124,2	215,9	50,8	31,8	12
E1M-3955-01	180	190,5	185,4	297,2	101,6	63,5	20
E1M-3956-01	320	190,5	183,4	297,2	101,6	63,5	20
E1M-3957-01	450	190,5	184,4	297,2	101,6	63,5	20
E1M-3958-01	450	209,6	199,3	365,0	50,8	34,9	20

1) the indicated natural frequency, are valid for the maxi loads of the ranges of use quoted in the paragraph : TECHNICAL CHARACTERISTICS.

VIB VHD 75

VERY HIGH DEFLECTION

LOW LOADS



DESCRIPTION

A range of multi directional mounts with very large deflection manufacture with elastomer and metal parts.

The elastomer is based on natural rubber which has been specially developed for marine applications.

ADVANTAGES

The mounts provide a high level of vibration isolation and shock attenuation. Their strenght is equal to a continuous acceleration of 10g at the maximum load. The range includes 5 references with load ranging from 11 to 94 daN.

The mounts meet the shock requirements for European and North American specifications. The metalwork is covered with elastomer to protect it against corrosion (ex. : salt fog).

DIMENSIONS

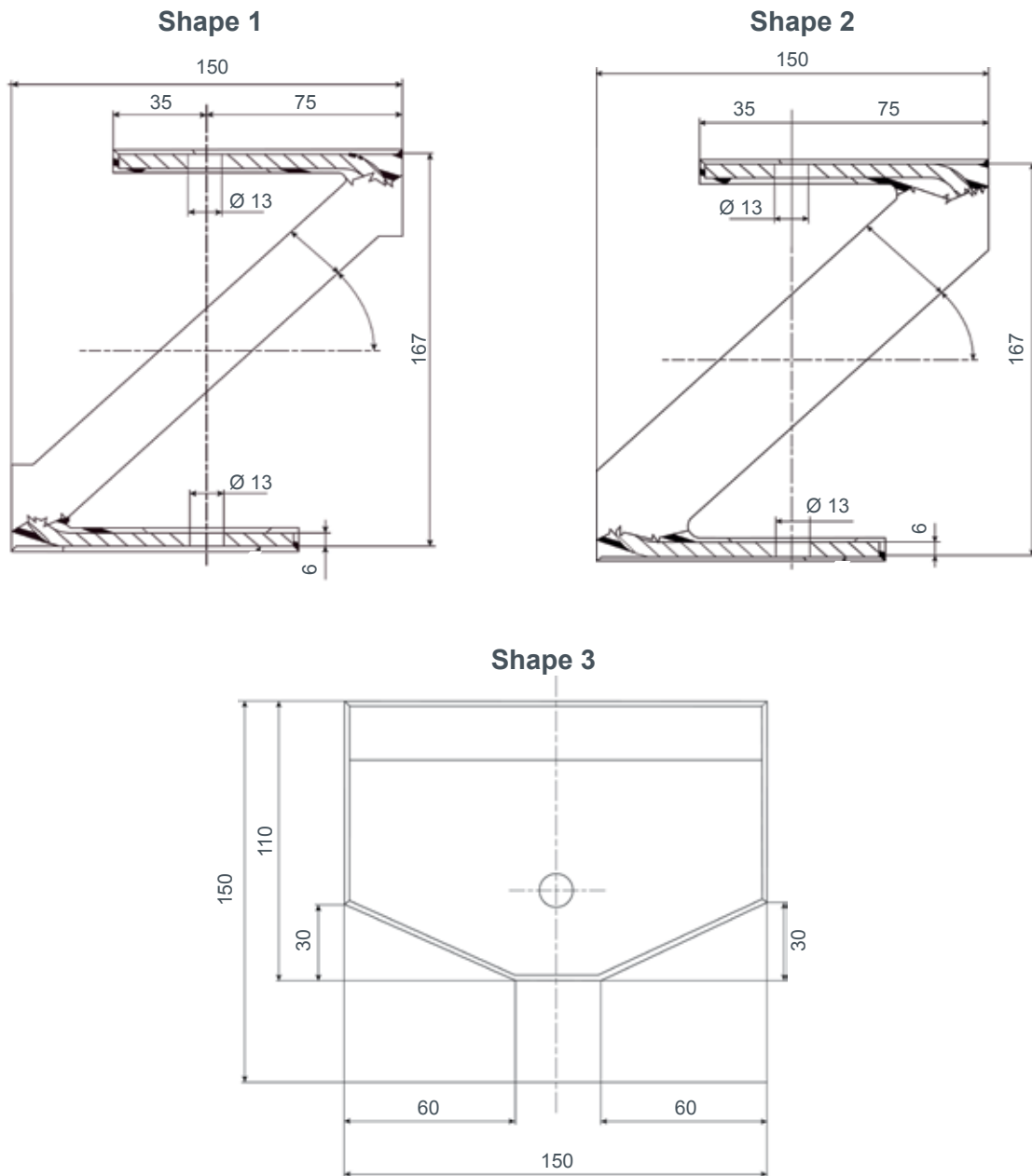

Static loads

Part numbers	Axial Z compression (daN)			Axial Z traction (daN)		Transversal Y (daN)	
	nominal	mini	maxi	nominal	maxi	nominal	maxi
552450	15	11,3	18,8	7,5	9,4	7,5	9,4
552451	25	18,8	31,3	12,5	15,6	12,5	15,6
552452	35	26,3	43,8	17,5	21,9	17,5	21,9
552453	50	37,5	62,5	25	31,3	25	31,3
552454	75	56,3	93,8	37,5	46,9	37,5	46,9

Longitudinal X : No permanent loads should be applied in this direction.

TECHNICAL CHARACTERISTICS

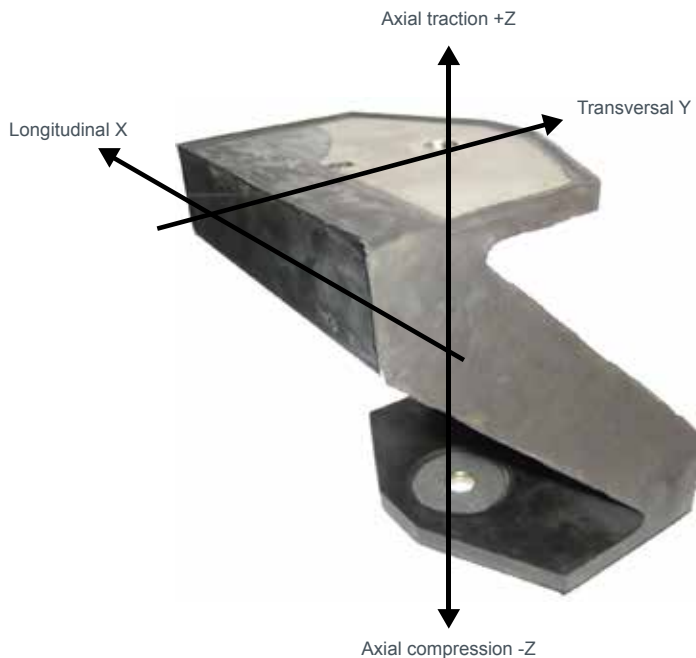

- Resonance frequency axial and radial : 5 to 7 Hz depending on load.
- Deflection during shock : 75 mm in all directions.
- Mechanical strength : 10 g with maximum load.
- Operating temperature : - 30 °C to + 80 °C.
- Metallic parts are covered with elastomer provide good corrosion resistance when used in a sea water environment.

ASSEMBLY

In the case of a large cabinet, the mounts can also be used as stabilisers. They should be fixed after the load has been supported by main mountings.

To ensure the mounting system operates correctly all connections should be capable of large displacements. We recommend that installation design should be approved by our technical department.

VIB VHD 75

HIGH DEFLECTION MOUNTINGS

HIGH LOADS

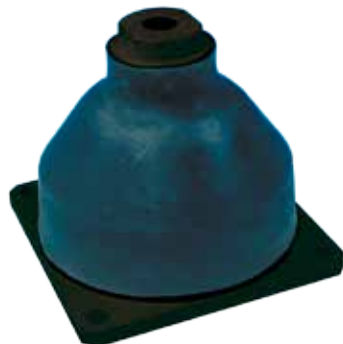

DESCRIPTION

Elastomer isolators designed for acoustic isolation and shock protection.

CHARACTERISTICS

- Natural frequency (vertical and lateral) under nominal load : 4 to 5.5 Hz.
- Maximum displacement under shock: 75 mm* all in directions.

* maximum forces corresponding to 15 times the nominal load

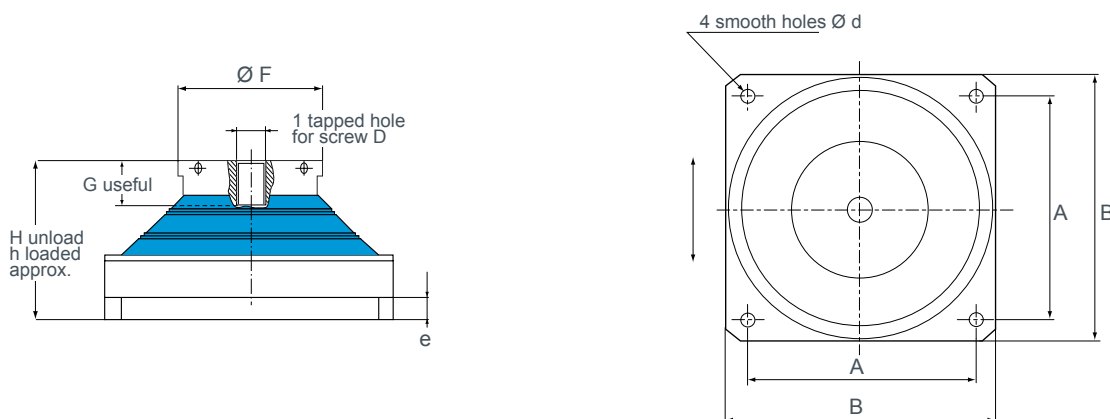

Nominal load (daN)	Reference	D	Ø F (mm)	G lenght useful (mm)	e (mm)	H unloaded (mm)	h under load (mm)	A (mm)	B (mm)	Ø d screw hole (mm)
120	E1N-3392-50	M30	92	45	15	211	197 approx.	200	236	18
200	E1N-3392-59	M30	92	45	15	211	197 approx.	200	236	18
250	E1N-3392-58	M30	108	45	15	211	197 approx.	234	270	18
380	E1N-3392-57	M30	112	45	15	211	197 approx.	234	270	18
630	E1N-3392-56	M56	199	84	40	255	238 approx.	360	446,5	30
900	E1N-3392-55	M56	199	84	40	255	238 approx.	360	446,5	30
1200	E1N-3392-54	M56	240	84	40	255	238 approx.	360	446,5	30
2000	E1N-3392-53	M56	240	84	40	255	238 approx.	360	446,5	30
3000	E1N-3392-52	M56	240	84	40	255	238 approx.	360	446,5	30
4000	E1N-3392-51	M56	280	84	40	305	289 approx.	460	546,5	30

Active control systems of noise and vibrations

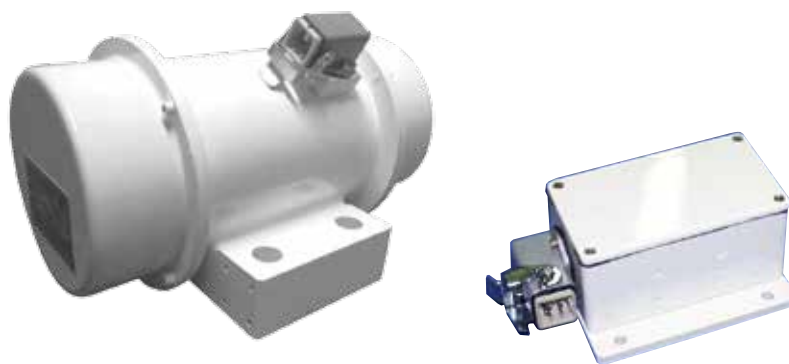

INTRODUCTION

Active isolators cancel the incoming vibration by generating a dynamic force of same magnitude in opposite phase through the use of electrodynamic actuators, thus improving the low frequency performance of the suspension.

The objective is to improve the insulation of vibration in the range 10 to 1000 Hz even more – according to the needs of the application.

The applications of STRACTIVE are endless : reactive silencer, electric motor, transformers, internal combustion engines, structures, pumps,...

EXAMPLES OF APPLICATIONS

- Oceanographic research vessel : improves the threshold of sonar detection.
- Extends crew shift.
- Submarines : reduce noises.
- Diesel engines / ventilation systems : reduction of air noises by active silencers.
- Machine tools : improvement of precision and life cycle of manufacturing tools.

ADVANTAGES

- To improve dynamic isolation offered by passive suspensions of the same stiffness.
- To improve uncoupling between structures.
- To simplify the installation of the equipment by reducing or eliminating inertia blocks.
- To reduce structural stress and increase life.
- To reduce noise.
- To reduce movement of connections to equipment
- Excellent vibration reduction : 12 to 36 dB of additional filtering compared to the passive solution only.
- Total suppression of the most annoying harmonic.
- Performance upgrade of existing machines with minimum impact (Add-on kit).
- Space & weight saving.
- Improve the professional environment in term of noises and vibrations exhibition.
- Reduce submarines noises.

PRINCIPLE

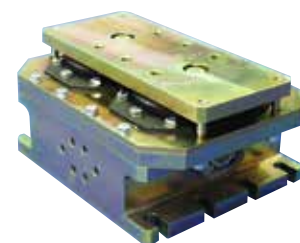
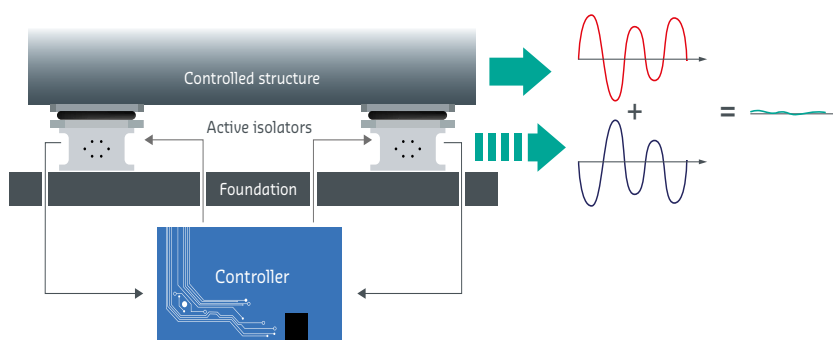
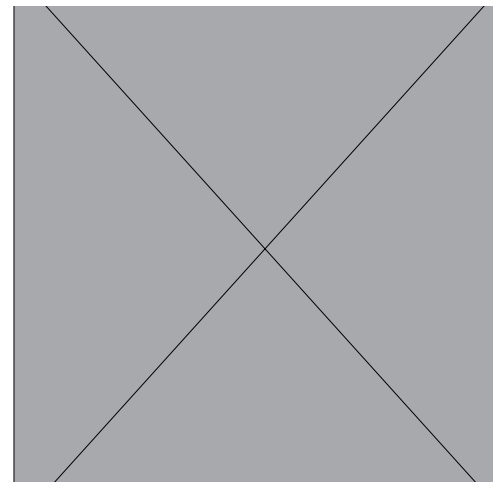
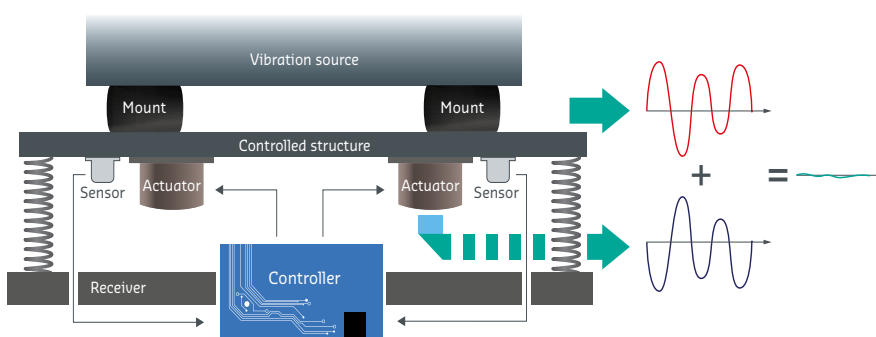

PRODUCTS

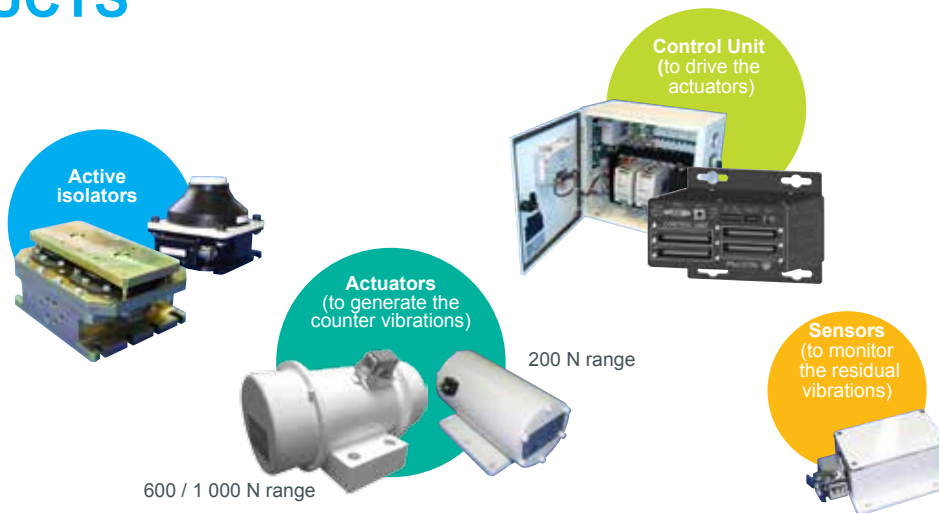

EXAMPLES OF RESULTS

Active Vibration Control Test Results

